

Heat Transmission of Double-Pane Windows with Horizontal Slats in Thailand

Vichuda Mettanant¹, Pipat Chaiwiwatworakul¹

Received: 12 June 2015; Accepted: 13 July 2015

Abstract

An automated blind can provide energy saving and better comfort. To obtain these benefits a computer program that is able to calculate interior illuminance, heat gain, glare discomfort and thermal comfort has been developed. The thermal performance of the window system was investigated. From the study it is found that installing a venetian blind in between the double-pane glass window causes a significant reduction in heat gain compared to the plain glass window. The heat gain through the window system in the shortwave part of the radiation is analyzed. The slat reflectance, slat angle and solar profile angle are the major affect on the shortwave part of solar heat gain coefficient. The blind using a lower value of slat reflectance has a lower shortwave part of solar heat gain coefficient. The effective solar heat gain coefficient (SHGC) and the effective overall heat transfer coefficient (U) for the double-pane glassed window with enclosed horizontal slats was developed. These SHGC and U value can be used with the equation to calculate the Overall Thermal Transfer Value (OTTV) of Thailand's building energy code to evaluate a building that use the double-pane glassed window with enclosed venetian blind.

Keywords: automated blind, solar heat gain coefficient, overall heat transfer coefficient

Introduction

Venetian blinds are popular shading devices used in commercial buildings. Blinds facilitate daylight into building by blocking excessive light while views are still possible. Utilization of daylight increases worker satisfaction and productivity. For tropical climate or summer conditions daylight is highly available and buildings are cooling load dominated. Daylight can be used to replace electric light; reduce electricity consumption for lighting and cooling system. However heat gain due to solar radiation is an important part of cooling load in Thailand.

Solar Heat Gain Coefficient (SHGC) measures how much heat from the sun is blocked. It is the fraction of incident irradiance that enters through the window and becomes heat gain. It includes both the directly transmitted portion and the absorbed and reemitted portion^{1,2}. The SHGC and the U values are significant factors for rating of fenestration² and also used for building design and rating^{3,4}.

The results of Klems and Warner⁵ confirmed that the SHGC for fenestrations incorporating venetian blinds depends strongly on the incident direction of beam solar radiation. Using a single value of SHGC to characterize window with blind systems would lead to nonsensical energy choices. However, the study was conducted only at few slat angles.

Therefore, in this study an investigation of thermal performance of the window system was evaluated and the effective SHGC and the effective U values were developed and analysis in detail based on weather of Thailand.

Thermal Performance of Venetian Blind Window System

The heat transfer through venetian blind window system can be written as⁶

¹ Joint Graduate School of Energy and Environment, King Mongkut's University of Technology Thonburi, Bangkok, Thailand
E-mail: vichuda.mettanant@gmail.com

$$q = SHGC \times I + U \times \Delta T \tag{1}$$

Where q is the heat gain (W/m^2). SHGC is the solar heat gain coefficient. U is the overall heat transfer coefficient ($W/(m^2 \cdot K)$). ΔT is the temperature difference between the indoor and outdoor condition (K). I is the incident solar radiation (W/m^2). The solar heat gain coefficient for a venetian blind window system can be divided into the solar heat gain coefficient in the shortwave part and the solar heat gain coefficient in the longwave part.

In this analysis the effect of the slat reflectance, slat angle and solar profile angle on the SHGC of the direct solar radiation of the system of glass window and blind are investigated. The solar profile angle is the relationship between the solar altitude angle and the solar azimuth angle. The solar profile angle can be written as

$$\phi_s = \tan^{-1} \left(\frac{\tan(\alpha_s)}{\cos(\gamma_s - \gamma_w)} \right) \tag{2}$$

Where f_s is the solar profile angle. a_s is the solar altitude angle. g_s is the solar azimuth angle. g_w is the window azimuth angle. The solar heat gain coefficient (SHGC) and the solar heat gain coefficient in the shortwave part (ShW SHGC) for the fenestration system are calculated from the developed mathematical model as presented in⁷.

(Figure 1) to 3 show the variations of SHGC for venetian blind at 0° , 45° and -45° , respectively. The SHGC of the single pane clear glass window is also shown for comparison. The results show that the SHGC of the clear glass window and window with venetian blind are dependent on the solar profile angle. The dotted lines in (Figure 1-3) represent the shortwave transmittance for the direct radiation indicated as solar heat gain coefficient in the shortwave part (ShW SHGC). The differences between the solid and dotted lines in (Figure 1 to 3) are the values of longwave transmittance for the direct radiation which are shown as the values of the solar heat gain coefficient in the long wave part.

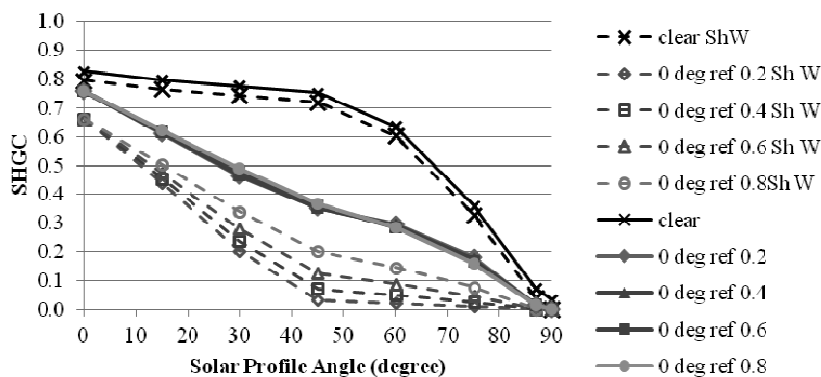

Figure 1 SHGC and ShW SHGC of the window with blind in different slat reflectance when the slat is set at 0° . ref = slat reflectance. Clear = clear glass window.

From the results the SHGC values of clear glass pane are higher than the window with blinds. For single pane clear glass window, the values of solar heat gain coefficient in the shortwave part are dominant and the values of longwave part of SHGC are small when it is compared to the window with blind. The ShW SHGC is high when the slat is in the position that the slats are able

to reflect radiation into the room. In any case, the values of ShW SHGC are low at the low slat reflectance values because the slat can reflect lower ration into the room.

The effect of slat reflectance on SHGC is low when the slat is in position that solar radiation do not incident on the slat or at the slat position that most of the solar radiation is blocked by the slat.

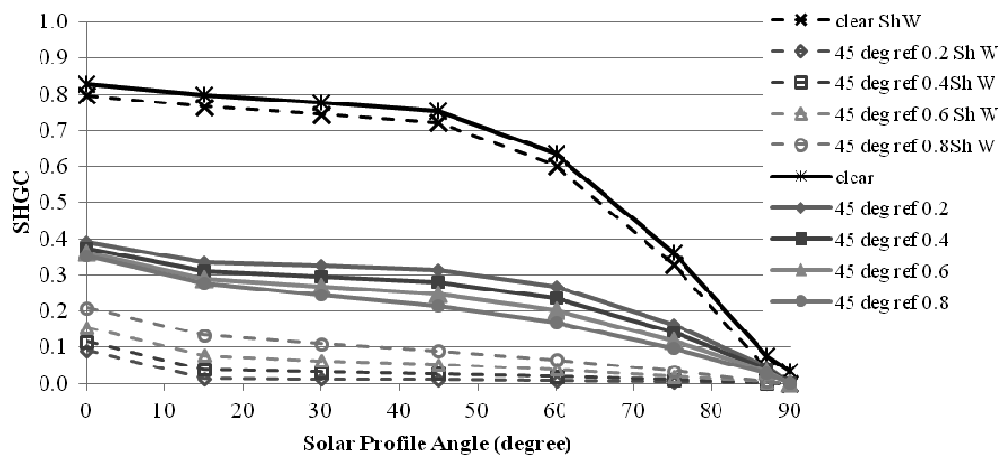

Figure 2 SHGC and ShW SHGC of the window with blind in different slat reflectances when the slat is set at 45°. ref = slat reflectance. Clear = clear glass window.

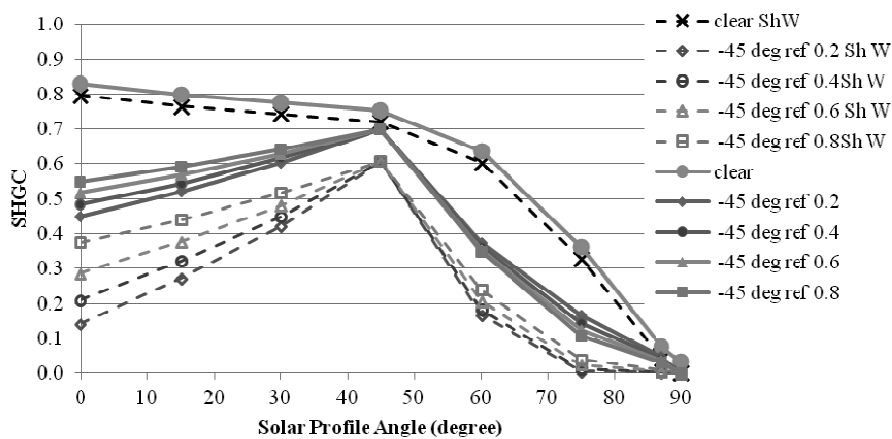

Figure 3 SHGC and ShW SHGC of the window with blind in different slat reflectances when the slat is set at -45°. ref = slat reflectance. Clear = clear glass window.

Effective SHGC and Effective U-value

The one year weather data of Bangkok are used for the simulation. Wind speed is set as 1.5 m/s. The type of window system used in this section is double glazing window filled with air in the gap using green glass as exterior window and clear glass as interior window with venetian blind in between. The properties of glazing are summarized in (Table 1 and 2). For simulation the configuration of the room is as shown in (Figure 4). The walls, roof and ceiling are well insulated.

Thermal properties of glass pane and blind slat are shown in (Table 1). Thermal properties include of thermal conductivity (k), specific heat capacity (c_p), density (r) and thickness. (Table 2) shows properties of glass panes, and blinds including transmittance (t), absorptance (a) and reflectance (r) as solar and visible properties and also emissivity (e). The properties of front and back sides of glasses are the same.

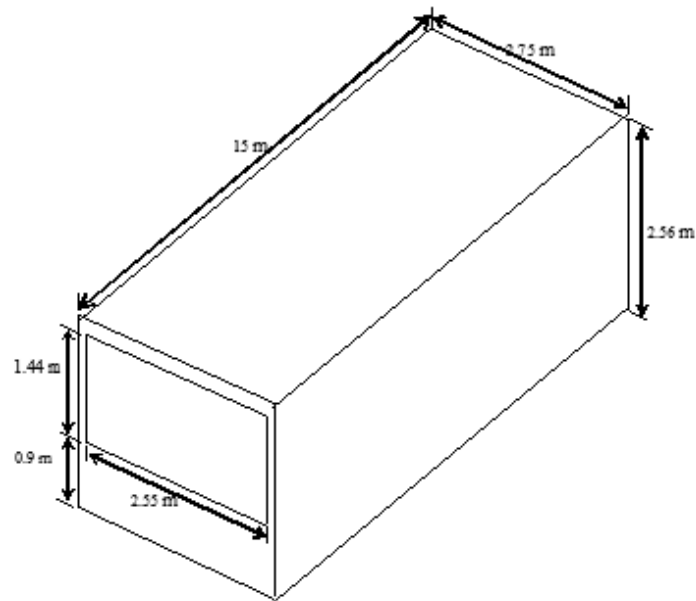

Figure 4 Building configuration

Table 1 Thermal properties of glass panes and blind slat

| Material | k W/m.K | c_p kJ/kg.K | ρ kg/m ³ | Thickness m |
|------------|--------------|------------------|-----------------------------|----------------|
| Glass pane | 1.05 | 0.840 | 2500 | 0.006 |
| Blind slat | - | 0.870 | 2700 | 0.001 |
| | | | | |

Table 2 Solar and visible properties of glass panes and blind slat

| Section | t | α | ρ | ϵ |
|-----------------------|------|----------|--------|------------|
| Clear glass (solar) | 0.80 | 0.13 | 0.07 | 0.85 |
| Clear glass (visible) | 0.80 | 0.12 | 0.08 | - |
| Green glass (solar) | 0.26 | 0.68 | 0.06 | 0.85 |
| Green glass (visible) | 0.67 | 0.21 | 0.12 | - |
| Blind slat(solar) | 0 | 0.316 | 0.684 | 0.316 |
| Blind slat (visible) | 0 | 0.266 | 0.774 | - |

The blind chosen for this study is a 50 mm venetian blind. The distance between the between two glass panes is 100 mm. (Figure 5) shows the position of blind when the slat angle is positive with slat tilt angle

b. (Figure 5) also illustrates slat width and distance between each slat (slat separation) which are 0.05 m and 0.042 m, respectively.

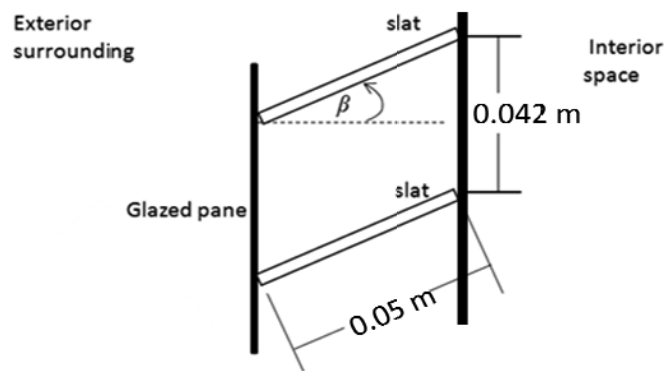

Figure 5 Side view of two adjacent slats

The developed computer program was used to calculate heat transfer through double-pane window with blind. The values of monthly average of the window heat gain are shown in (Figure 6). At high degrees of blind angles such as -50, -60, 50, and 60 degree, heat gain through window reduces because the blind slats are almost close and beam radiation cannot penetrate through

the gaps between blind slats. It is found that there are the higher values of heat gain through the window system in the cases of positive slat angles when comparing to the cases of negative slat angles. When blind angles are negative, there are higher chances that blind slats tilt parallel to the direction of beam solar radiation so higher heat passes through the window system.

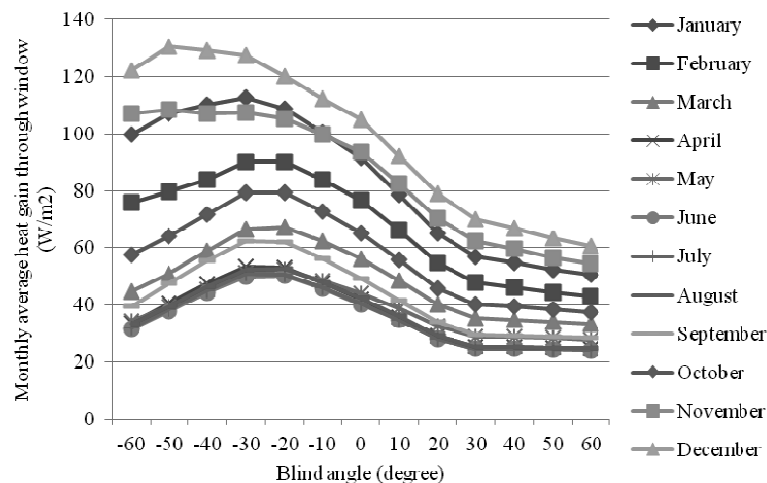

Figure 6 Monthly average heat gain through window (south orientation)

The effective SHGC and U-value are calculated by using Equation 1 divided by the solar radiation incident on window in vertical direction (*I*):

$$\frac{q}{I} = SHGC + U \times \frac{\Delta T}{I} \tag{3}$$

(Figure 7) shows the plot of the ratio between heat gain through window and the solar radiation incident on window in vertical direction and the ratio between the

temperature difference between the indoor and outdoor air and the solar radiation incident on window. Each dot in the graph represents the data at a particular hour. The slope of the data in (Figure 7) is the U-value and the intercept of the graph is the SHGC. One set of data in the case of 0 degree blind angles in October is shown as an example. Each graph provides the SHGC and the U-value for a particular month and a particular slat angle.

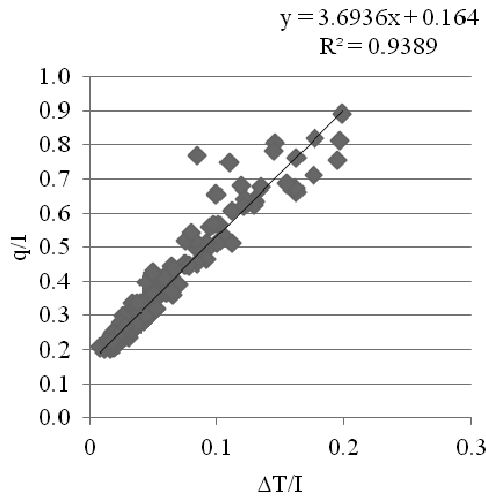

Figure 7 q/l and DT/l in October at 0 degree slat angle

The effective SHGC values and the effective U-value of each month and each blind angle are shown in (Figure 8 and 9), respectively. The results are analyzed for the data during the daytime (8 a.m. to 7 p.m.) and the profile angles are in the range of 22-90 degree. The

yearly average profile angle during daytime is 63 degree. It was found that the results were high when the blind angles were negative which is in agreement with the results shown in (Figure 1 to 3).

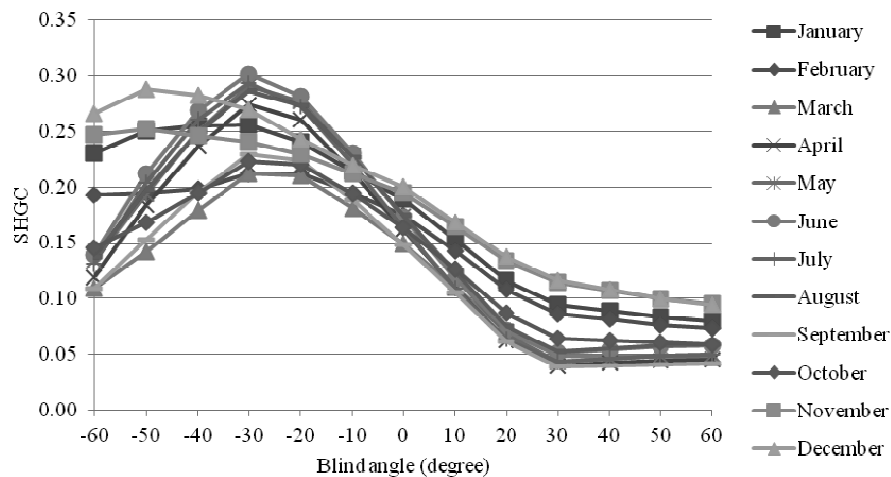

Figure 8 The monthly effective SHGC of the double-pane window with blind

When blind angles are negative, the shortwave part of SHGC is dominant. When blind angles are positive, the longwave part of SHGC is dominant because most of the solar radiation is blocked by the slat.

During the daytime (8 a.m. to 7 p.m.), an average temperature difference between the indoor and outdoor conditions is 7.3 °C when the indoor temperature is set

as 25°C. When slat angles are positive, the effective U-values are highest at 0° blind slat angle and decrease when the blind angle increases. As the blind closes, increasingly it blocks the direct exchange of longwave radiation between the glass panes. This is probably the dominant effect that causes the decrease in U-value as the blind is closed.

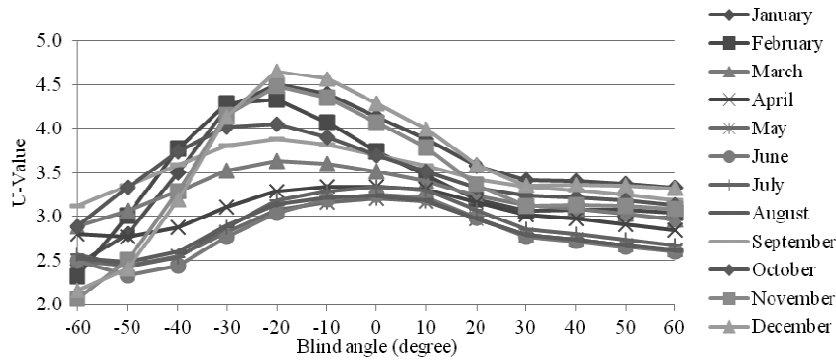

Figure 9 The monthly effective U-value of the double-pane window with blind

Applications of Effective SHGC and U-value

The results of the effective SHGC and the effective U-value in the previous section can be used to calculate the heat gain through window (W/m^2) by Equation 1. The case of January 1st when blind angle is -30° is selected as an example. The effective SHGC and the effective U-value for January are 0.256 and 4.233, respectively. The room air temperature is set as $25^\circ C$. The ambient air temperature and solar radiation incident

on window on the selected day are shown in (Figure 10). The heat transfer through window on the selected day is shown in (Figure 11). The heat transfer through window calculated by the computer program that is based on the heat balance equation, and the radiative exchange equation is also shown in (Figure 11) as a dotted line. The results from Equation 1 show good agreement with the results from the computer simulation program at maximum 7.8% error.

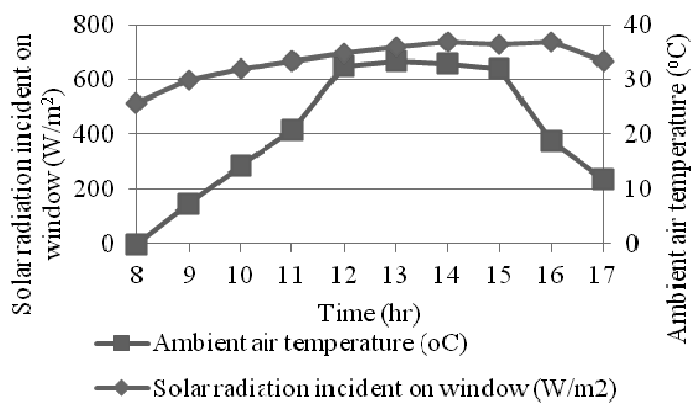

Figure 10 Ambient air temperature and solar radiation incident on window of the example date

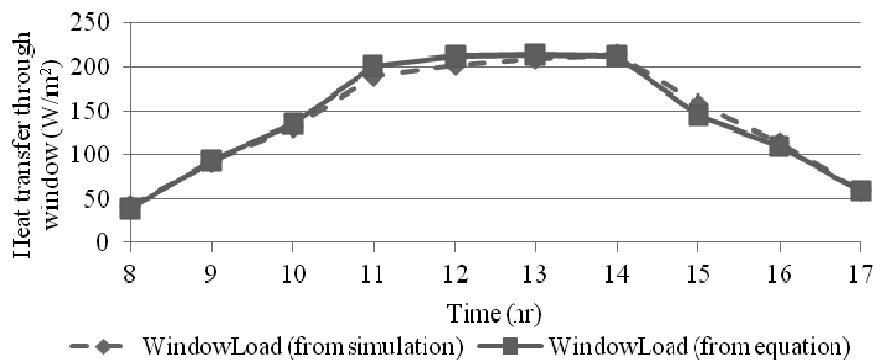

Figure 11 The heat transfer through window on the example date

The effective SHGC and the effective U-value in (Table 3 and 4) can also be used for calculation of the Overall Thermal Transfer Value (OTTV) in the building energy code of Thailand. The terms of the total thermal transmittance (U_f) and the solar heat gain coefficient (SHGC) of the OTTV equation can be calculated when double-pane windows with venetian blind are used.

Conclusion

The SHGC and U-value for calculation of heat transfer through window systems was developed.

The directly transmitted portion of Solar Heat Gain Coefficient (SHGC) and the SHGC that includes the both directly transmitted portion and absorbed and reemitted portion of SHGC were analyzed. The results show that the SHGC are dependent on the solar profile angle and blind reflectance. The monthly effective SHGC values and the monthly effective U-value of white aluminum blind are developed. The heat transfer through window estimated from the developed effective SHGC and effective U-value show well agreement with the heat transfer through window calculated by the computer program that is based on the heat balance equation and the radiative exchange equation at maximum 7.8% error. These SHGC and U value can be used to calculate the Overall Thermal Transfer Value (OTTV) of Thailand's building energy code for a building that use the double-pane glassed window with enclosed venetian blind.

References

- [1] ASHRAE, ASHRAE Handbook Fundamentals, American Society of Heating, Refrigerating and Air-Conditioning Engineers, Inc. Atlanta, Georgia, 2005.
- [2] The National Fenestration Rating Council, Energy Rating, Retrieved from www.nfrc.org, 2015.
- [3] Li, D. H.W., Lam, J. C., Solar heat gain factors and the implications to building designs in subtropical regions, *Energy and Buildings*, 2000; 32(1): 47-55.
- [4] Chirattananon, S. and Taveekun, J, An OTTV-based Energy Estimation Model for Commercial Buildings in Thailand, *Energy and Buildings Journal*, 2004; 26: 680-689.

- [5] Klems, J. H. and Warner, J. L., Solar Heat Gain Coefficient of Complex Fenestrations With a Venetian Blind for Differing Slat Tilt Angles, *ASHRAE Transactions*, 1997; 103(1): 1997.
- [6] Chaiyapinunt, S. and Khamporn, N., Heat transmission through a glass window with acurved venetian blind installed, *Solar Energy*, 2014; 110: 71-82.
- [7] Fathoni, A.M., and Chaiwiwatworakul, P (2011) Double-Pane Window with Internal Fixed-Angle Slats for Daylight Application in the Tropics, Master-degree Thesis, Joint Graduate School of Energy and Environment, King's Monkut University of Technology, Thonburi.