

Snubber Circuit Used as the Temperature Dissipation of Mosfet for Electric Car Drive System

Sakrawee Reweekul¹

Received: 29 June 2015; Accepted: 13 July 2015

Abstract

This article presents a method to reduce the temperature of a mosfet by using a snubber circuit as the electric current dissipation of the switching current for motor speed control. The switching current during $t_{on\ state}$, and $t_{off\ state}$ of the mosfet can cause high power dissipation. This can damage the mosfet. In addition, in the $t_{off\ state}$ the mosfet is not conducted, there are some voltages across the mosfet that also can damage it when the voltage exceeds the mosfet voltage rating. This research therefore aims to study how to reduce temperature of the mosfet for an electric car drive system that employs paralleled mosfet in order to control motor speed continuously under a heavy load.

Keywords: snubber circuit, mosfet, parallel connected, electric drive, chopper, power dissipation.

Introduction

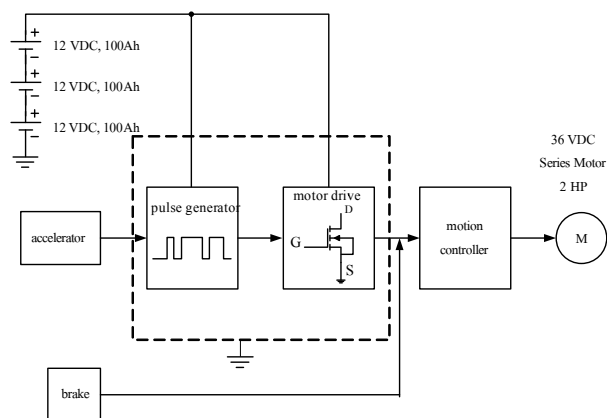

Figure 1 Block diagram of Electric car drive system

To control the speed of a direct current motor, there are many methods¹⁻³ for example by adjusting the value of a large current capacity resistor. This method is durable and needs fewer devices; This method requires high current capacity power electronic switch which can resist the instantaneous current during the switching times. The often used power electronic switches at present are mosfet and IPM. At present, the IPM is a module that is mostly used in the electric car drive system;

however, the drive circuit is expensive as well as the module itself.

Consequently, this research is to present an 8 – paralleled mosfet electronic switch used as the drive circuit which is inexpensive and durable.

However, a major problem of the paralleled mosfet is the limitation of the current tolerant. To carry the load current for a long time by each mosfet switch alone can damage the whole drive system and cause overheat, or burst^{4,5}.

This research is to study how to dissipate current for reducing temperature of the mosfet at the switches current during $t_{on\ state}$ and $t_{off\ state}$. By using a snubber circuit for a motor drive system employing paralleled mosfet for the speed control³. For the motor however, the high power loss is its disadvantage. Another method commonly used is to employ power electronic equipments as depicted in (Figure 1) drive system is inexpensive, requires less maintenance, and can be operated continuously when using a 2HP 36 VDC motor⁶. This article is divided into 4 parts, 1. Analysis of the drive system, 2. Design of snubber circuit, 3. Experiment, and 4. Conclusion.

¹ Rajamangala University of Technology Isan (Khon Kaen Campus), Department of Electrical Engineering, 150 Srichan Road, Muang District, Khon Kaen, 40000, Thailand *corresponding author: Email: mr_sakrawee@yahoo.com

Drive system

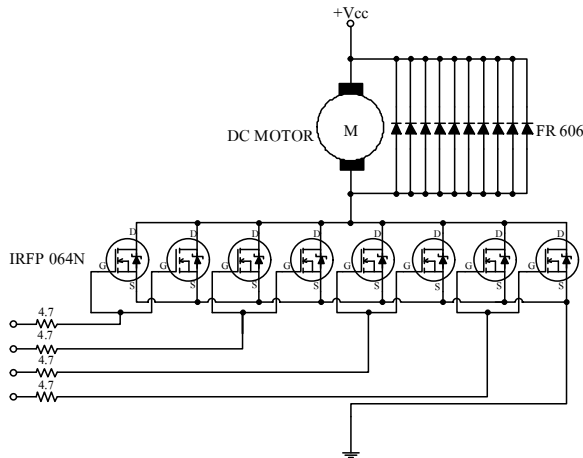

Figure 2 Switching mosfet switches

A switching power electronic circuit used as the direct current motor speed control is depicted in (Figure 2). The 8 mosfet switches are paralleled to control the electric car speed.

However, the driving system has a major problem at the high load at $t_{on\ state}$ and $t_{off\ state}$. While the mosfet conducts current as depicted in (Figure 3), a large current flowing through the mosfet can cause damage due to the overheating. At the off state, a large amount of voltage is across mosfet, if the voltage across the mosfet is for too long a time, damage due to the overheat can occur. Especially, for the paralleled case, each switch has a limitation of current tolerant; so, damage in one switch that can affect the whole drive system.

Snubber Circuit Design

Due to the problem mentioned above, the research aims to study and design a snubber circuit that is tolerant to over current or over voltage, and when there is the instantaneous change in both amplitude and rate of change. The designed snubber circuit has been divided into 2 sections: the over current protection and the over voltage protection. The details of each section are as follows;

The over voltage protection (turn-off snubbers) is depicted in (Figure 4). To protect the circuit from the instantaneous voltage, a resistor is series with a capacitor and then paralleled with the mosfet which is called a snubber circuit. The resistor and capacitor parameters can be calculated by

$$\text{capacitor } C_{S1} = \frac{I_o t_{fi}}{2V_d}, \text{ resistor } R_S < \frac{t_{onstate}}{2.3C_S}$$

where

- C_{S1} Snubber Circuit Capacitor
- I_o Motor current at starting of a 200 kilograms load, 60 A
- $t_{fi} \approx t_{ri} t_{off\ state}$ of the mosfet which is around the starting time
- V_d Motor rated voltage 36 volt
- R_S Snubber circuit resistance
- $t_{onstate}$ Current conducting period
- 2.3 Time interval the capacitor can totally discharge

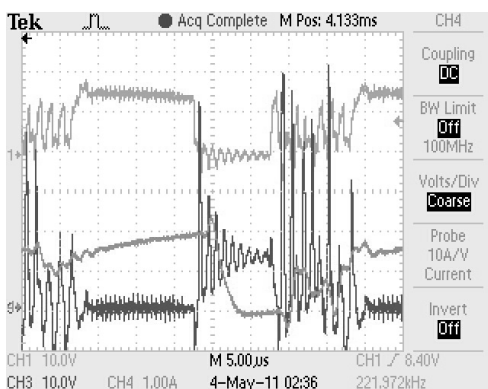
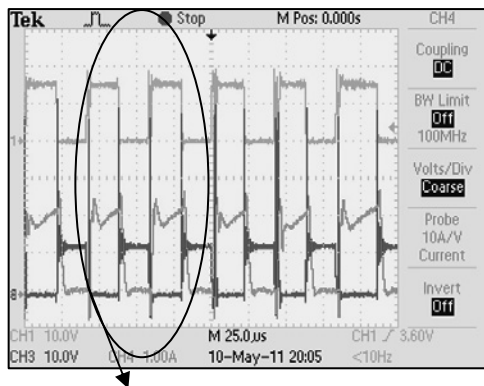

Figure 3 Voltage and current signals of Vgs, Vds, and Id from the experiment

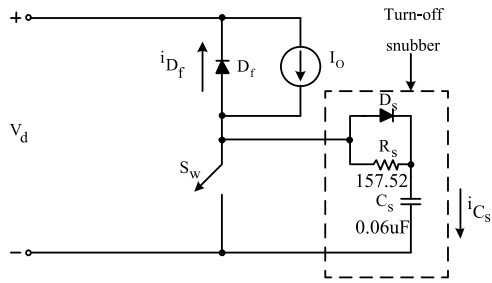

Figure 4 Over voltage protection circuit

However, a diode should be connected parallel with the resistor for the recovery time of the snubber circuit.

Under the surge voltage, the diode will conduct the current to pass through the capacitor. The capacitor will then behave like it is operating under the short circuit, which help reduce the voltage in the snubber circuit by allowing the voltage to be over itself. Under a normal operation when the capacitor is charged, the current will pass through the mosfet. When the capacitor is fully charged, the current will stop passing through the capacitor but it will flow through the whole circuit,

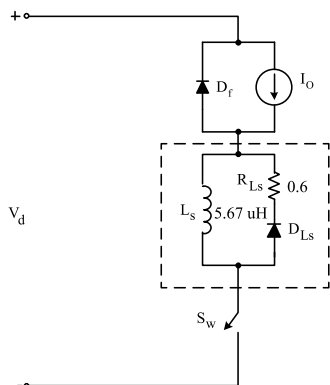

Figure 5 Over current protection circuit

the diode, and the resistor. The resistor helps reduce the current oscillation and limits the current under the current conducting period. However, at initial the capacitor will discharge the current into the circuit and the diode will help reduce the instantaneous current at the recovery.

To design the over current protection circuit (Turn-On Snubbers), the initial current (di/dt) is high and greatly damages the circuit system, therefore, as depicted in (Figure 5), an inductance (L_s) is serried with

a drain gate to reduce the rate of current. The energy is stored in the inductance and then will be transformed into heat. The inductance value can be calculated by

$$\text{resistor } R_{LS} = \frac{V_d}{I_o}, \text{ inductor } L_S < \frac{t_{\text{offstate}}}{2.3} R_{LS}$$

where

L_S Snubber Circuit Inductance

t_{offstate} Current conducting period

$t_{\text{fi}} \approx t_{\text{ri}}$ $t_{\text{off state}}$ of the mosfet which is around the starting time

R_{LS} Snubber Circuit Resistance

V_d Motor rated voltage 36 volt

I_o Motor current at starting of a 200 kilograms load, 60 A

2.3 Time interval the capacitor can totally discharge

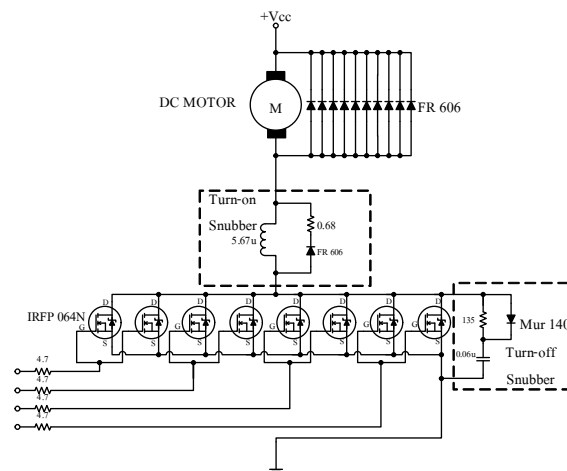

Figure 6 The equivalent circuit of the system

As you can see the depicted in (Figure 6) above, using snubber circuit can dissipate the over current in over shoot during during $t_{\text{on state}}$ and in under shoot during $t_{\text{off state}}$ for reducing temperature of the mosfet.

Materials and Methods

The experiment is conducted by connecting a snubber circuit with a motor speed control circuit of an 2 HP electric car rated (Figure 6) and (Figure 7) The duty cycle of a square wave pulse generating circuit can be adjusted through the 10kW resistor. The output pulse of the circuit then will be

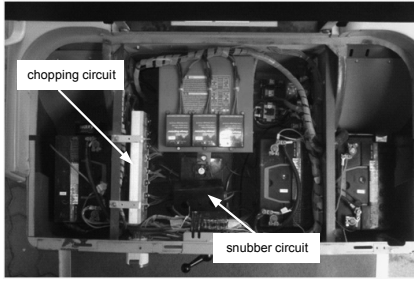

Figure 7 The electric car drive system of 2 HP 36 VDC rated

amplified and used to control the switching circuit; therefore, the motor voltage is able to change and vary according to the duty cycle of the square wave pulse generating circuit.

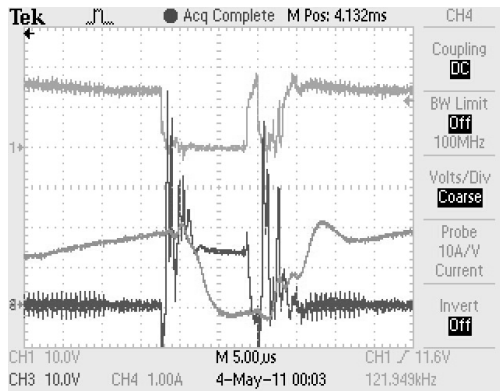

Figure 8 Signals of Vgs, Vds, and Id after connecting Turn on, Turn off Snubber circuits.

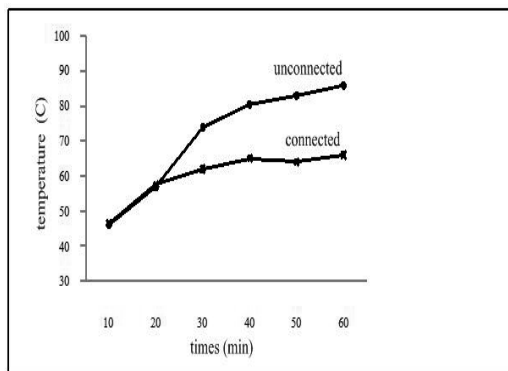

Figure 9 Comparison of temperature (heat) on the mosfet

The experiment results of adjusting the duty cycle of motor are depicted in (Figure 8) and the comparison of heat stored in the mosfet is depicted in (Figure 9).

Conclusion

From the experiment of the system after connecting the designed circuit, Turn On Snubber and Turn Off Snubber Circuits were observed for the Vgs and Vds of the mosfet under various duty cycles. The result of the experiment shows that whether the designed circuits are connected the overlapping of the voltages is low. However, the signals Vgs, Vds, and Id perform better responses when the designed circuit is connected, especially the Id that is decreased apparently, which helps reduce loss in mosfet while conducting the current. Besides, the voltage Vp that is able to damage the mosfet can also be reduced. Consequently, it can be concluded that to yield the best efficiency of the switching circuit, both of the snubber circuits should be connected.

Acknowledgement

Following the research was funded from Rajamangala University of Technology Isan, (RMUTI) Khon Kaen Campus. The purposes of the project are promotion and sustainable development in the industrial sector of Thailand and effective results. I would like to express my sincere appreciation for my co-researcher and my assistant researcher for contributing enormous intellectual and emotional support which led to the project’s success. Moreover, I would also like to express my gratitude to Electrical Engineering of the Faculty of Engineering for ure of their equipment and instruments.

References

- [1] C.W. Lander. *Power Electronic*.McGraw – Hill, England,3rd edn, 1997.
- [2] Rahim,N.A, Operating of Single-Phase Induction Motor as Two-Phase Motor, *IEEE Trans. On Industry Applications*, 2002; 38(6) 1566–1571.
- [3] Correa, M.B.R. Jacobina, C.B. Lima, A.M.N. and da Silva.E.R.C. Single-phase induction motor Drives systems, *IEEE Applied Power Electronics, Conference and Exposition(APEC '99.)*,Vol. 1, 1999, 403 – 409.
- [4] B.W. Williams. *Power Electronic*, The Macmillan Press,England 2nd edn, 1992.
- [5] M.H. Rashid. *Power Electronics : Circuits, Devices and Applications*. Prentice-Hall, USA,2nd edn,1993.
- [6] Krishnan,R. *Electric Motor Drives Modeling, Analysis and Control*, Prentice Hall, 2001.