

## Design and Development of a Small 3D Scanner

Sivapong Phetsong<sup>1</sup>

Received: 30 June 2015; Accepted: 13 July 2015

### Abstract

This research designed a simple 3D Scanner. The machines dimensions are 500x500x500 millimeters. The scanning area is 50x50x50 millimeters. The system has been integrated with C# language to create interface software, microcontroller for control stepping motor, webcam camera for capture reflection from laser, math algorithm to calculate coordinate between several types of coordinate and also integrate with image processing algorithm. In the experiments, we use laser shoot directly to object and take a picture of the reflection. We can then calculate the distance and point on surface. The machine take about 3 minutes to complete the scanning process. We also use the mesh formation software to create point cloud from data that we collect. And we also let that software to reconstruct point cloud to model surfaces. The result show that 3D Scanner has 1 millimeter accuracy with 4.6% error.

**Keywords:** 3D Scanner, Stepping motor, Laser, Microcontroller, Point Cloud

### Introduction

The reverse engineering technique in the present day uses several techniques to reconstruct a 3D model in a computer. It used several techniques to make a copy of the original model, but the most relied on image processing. A vary famous technique uses laser to measure the distance from point to point in the two local coordinate systems. With these steps, the reconstruction process of the model becomes very fast and easy. The three famous techniques used in a 3D Scanner are Laser Scan, photogrammetric and the combined technique of Laser Scan and photogrammetric<sup>1-6</sup>. The machine places a laser line on the object and uses a webcam to capture the laser line caused by the reflection on the object surface. The laser line displacement from the reference line will be measured by pixel count from photo<sup>1,3-7</sup>. This distance will reflect the distance from the axis in a polar coordinate. When software collects enough surface points from the calculation, it can create surface related to these point clouds. Finally, the system can reconstruct the 3D model in the computer. The user can use these 3D models to modify the original model or even pass it to other software.

By the way, the quality of the model also relied on laser and camera quality.

### Background and Fundamentals

#### 1. Image Processing

There are two type of picture files in the computer, vectors or raster. Vector image contain pixel position and surface information. With vector image, user can easily modify 3D model and also unlimited scale the image. Raster is always used with the photo because it collects every point in the pictures as a color pixel. When the system combines the individual pixel together, it becomes a photo. Each pixel can contain only one color level which the color level has been defined by file description, such as 8-bit or 24-bit color depth; the more color the more realistic. In the displaying process, Data in the files must be processed and applied to any image processing technique. First of all, Data will be changed to color at each pixel. Then it will be processed to improve the quality such as sharpen, smooth or noise removal. The technique required in the 3D scanner is to eliminate noise from picture and remove everything except the laser from

<sup>1</sup> Department of Mechanical Engineering, Faculty of Engineering and Industrial Technology, Silpakorn University Sanamchandra Campus, MuangNakornPatom, Thailand 73000 sivapong@su.ac.th, +6634 259025, +6634 219367

the pictures and convert to black color.

## 2. The Grey Scale

Grey Scale is one type of color depth. It contains several shades of color from white to black. It explains any pixel as a level of grey shade by white gradient. The user will notice the different color levels but grey scale uses less data than the color image. The color consist of three primary colors, Red, Green and Blue. Each primary can made 256 different shades. Converting the color image to grey scale, each pixel must be divided into three primary colors. Equation 1 is used to convert the color image to grey scale<sup>8,9</sup>. With this equation, the image looks as smooth as in color. (Figure 1) shows the converting process.

$$grey = (blue \times 0.11) + (green \times 0.59) + (red \times 0.30) \quad (1)$$

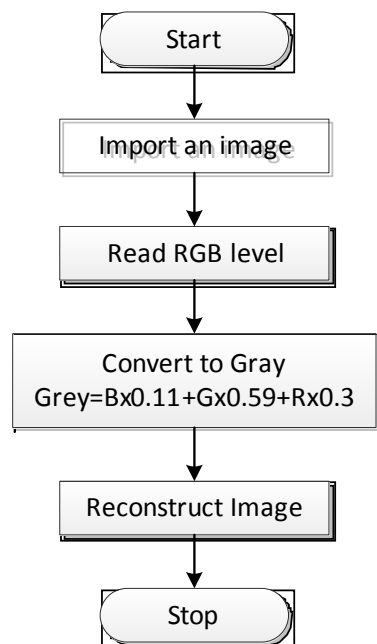

**Figure 1** Converting color images to grey scale.

## 3. Assembly point to picture

The coordinates we have can be assembled together to make a small surface called a polygon. Polygon requires at least 3 points in space to create. A model with a lot of polygons can create a 3D model. The more polygon the more realistic the 3D-Model. This can be easy explained by curvature surface<sup>10-12</sup>. If the curve has been divided in a few pieces, the polygons (or face), which are created by these points, are coarse. The

model will also be coarse. If this curve has been divided in a lot of piece, the polygons are small. The model will also be fine and realistic.

## Materials and Methods

### 1. The distance estimation

The process to create the 3D-Model back from the object and pictures. In this research, we use the distance calculation technique from the reflection of light. At first, we spot the laser to the object and take a picture of the reflection. Without any object in the experiment, the reflection of the laser line will be the vertical line at the reference point in x-direction. When we put the object in the experiment, the reflection shifts from the reference point to the right. We can then count back the distance from the reference point in x-direction in the unit of pixels. It is the distance from reference point.

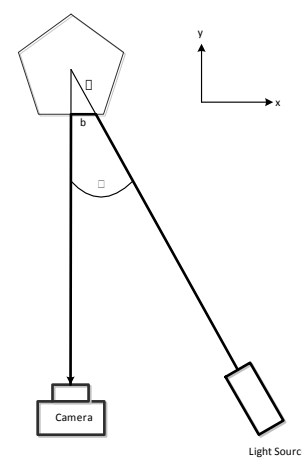

**Figure 2** Position of camera, object and laser.

The structure of the machine fixed the angle between the axis of the camera and the direction of the laser line to alpha (a) as shown in (figure 2). The value of rho (r) is the thing we need. It is the real distance in the cylindrical coordinate but we cannot measure it directly. We can calculate the (b) distance from the picture. As we know the distance in pixels between the reference points to laser point in the picture we took. We can calculate the pixel distance to the distance of b in millimeters<sup>2,3,13-15</sup>. With the assumption that the nonlinearity of distance to pixel is negligible. After that, apply Equation 2 to transform distance b to rho (r) which is the position in cylindrical coordinate.

$$\rho = \frac{b}{\sin(\alpha)} \tag{2}$$

Software will help us to calculate distance of every laser point in the pictures to surface position. Then the object will be turned around in a small angle. The process will be started again and recalculated at every point again. This process happens until the object has made a 360 degree turn. Then the scanning process is complete. Then Software recalculate all point into the rectangular coordinate by using the equation 3.

$$\begin{aligned} x &= \rho \cos(\alpha) \\ y &= \rho \sin(\alpha) \\ z &= z \end{aligned} \tag{3}$$

### 2. Machine Development

The development of the 3D Scanner can be separated into three parts, Machine Structure and hardware, Controlling Software and the image processing software. These three parts work independently of each other but are integrated in the same software to centralize control for the user. The device has a rotat base that can be rotated in z-direction to follow the cylindrical coordinates. The object size is 50x50x50 millimeters maximum allowance. It can turn 0.8 degree in each step. In the experiments, we use the red laser line to specified location. The results show that the machine can make detail up to 1 millimeter. (Resolution will be better with finer laser line and better camera.)

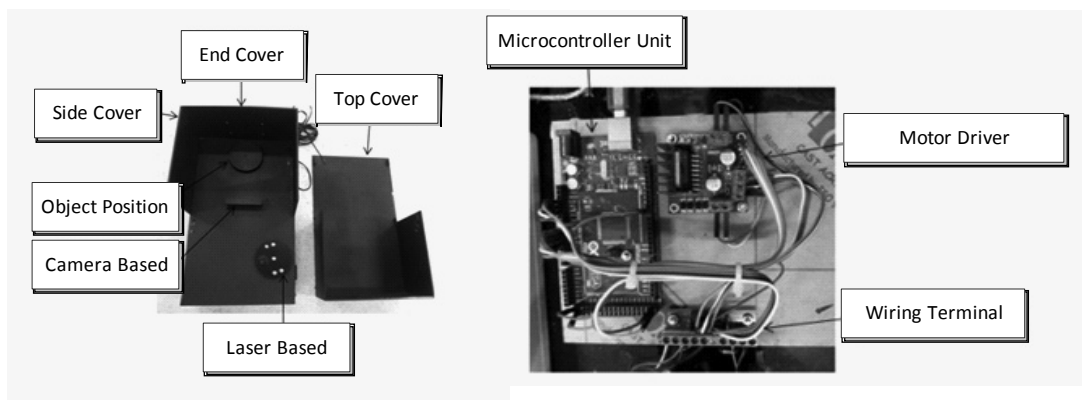

Figure 3 inside the scanner.

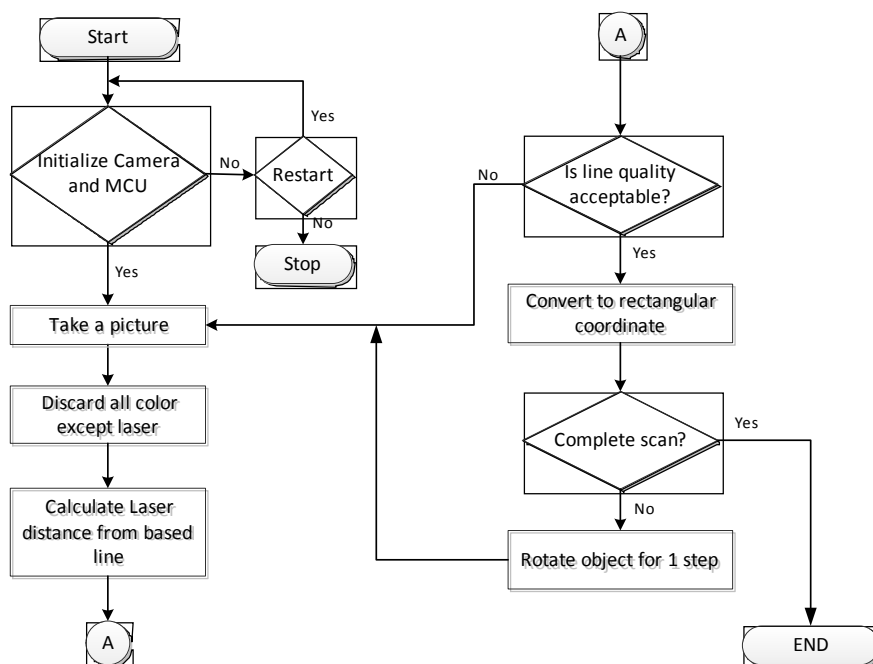
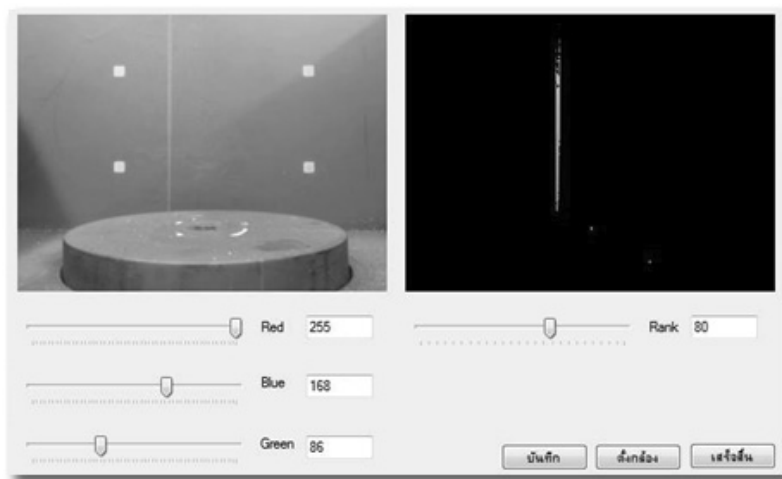

Figure 4 Flowchart of the Control software

The control software is used to control and interconnect the applications developed in C# with the software in microcontroller to control the camera, laser and the scanning machine. Software tries to connect to every device needed in the scanning process when it started. Then software get the picture from the camera and follows the process in the flowchart in (figure 4). The image processing technique has been applied at this point based on the laser color. Every color in the picture will be discarded except the laser color by using this image processing technique. At this point there is only one color left in the picture. Software will convert the picture to grey scale to reduce the processing time making it easy to analyze.

### 3. Calibration

Because of the differences of the picture makes from different camera model software has to be configured to make it suitable for the system. It requires user setting to the right color of the laser color. Then we have to make a reference point in the pictures and reference to the real position to make a reference for software calculation. These value are different in each camera because of the camera structure and camera lens<sup>16,17</sup>. In addition, we have to adjust the laser position and direction including the laser color, according to (figure 5), so that the reference position of the laser does not distort the laser line has to be sharp. This will directly affect the accuracy of coordinates obtained from the calculation.

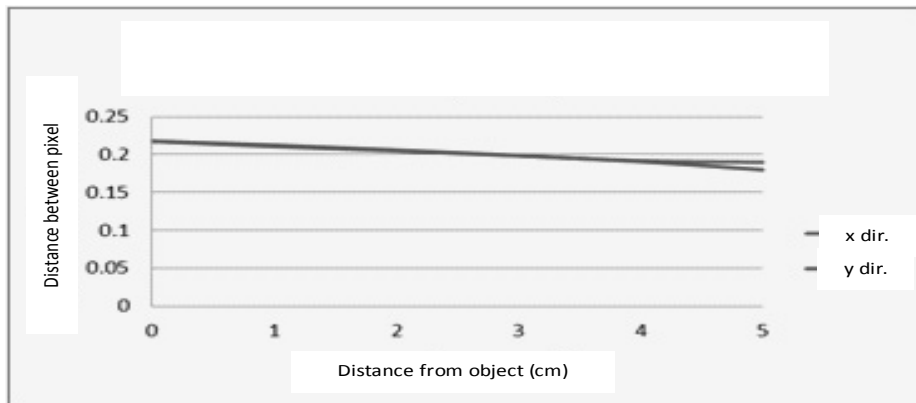

**Figure 5** Software interface in color setting

### Results

After the adjustment of the laser and camera. In the experiment with 360 degree angle with 0.8 degree per step, the machine take about 3 minutes to complete a scan. We try to plot the result coordinate and create polygon with point cloud software. The results show that

it is close to the original model. There are some errors in the result because of the relationship of the distance between pixels is proportional to the distance from the camera to the subject, which is not linear. When tested at various distances, we found a relationship of these two distance as in (figure 6).



**Figure 6** the variation of the distance between pixels at different stages.

The result from the simple object geometry scanning which we know dimension exactly. We founded that there is the slightly distorted due to the uncertainty

of the surface width per pixel. It was found that the maximum error of 9.42% on flat surface and the maximum error of 23% for hole size 1 mm.

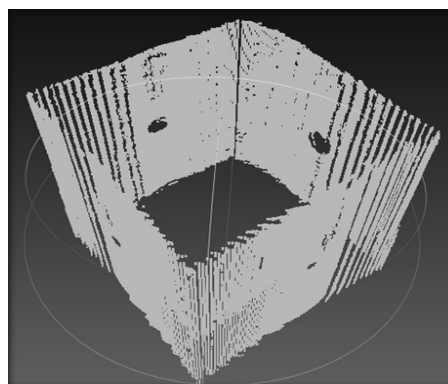
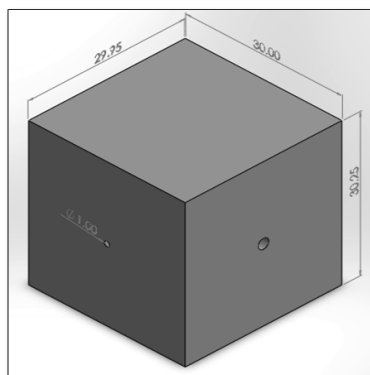

**Figure 7** rectangular object. Compared with the scanned model.

When compensation at various stages with the value from the chart in (Figure 6). We founded that the model is more accurate. The error of the pyramid shape

model is about 6.8% in the wide side. The cone model has maximum error about 4.6%

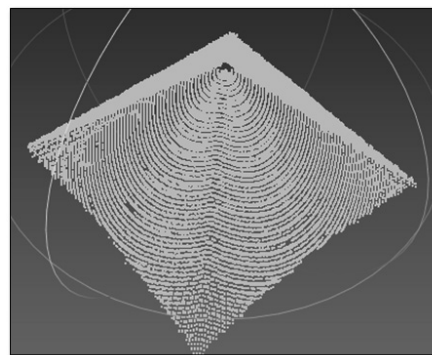
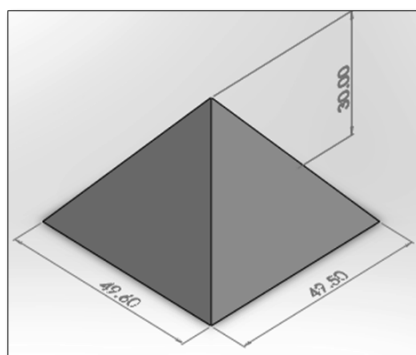

**Figure 8:** pyramid shaped object. Compared with the scanned model.

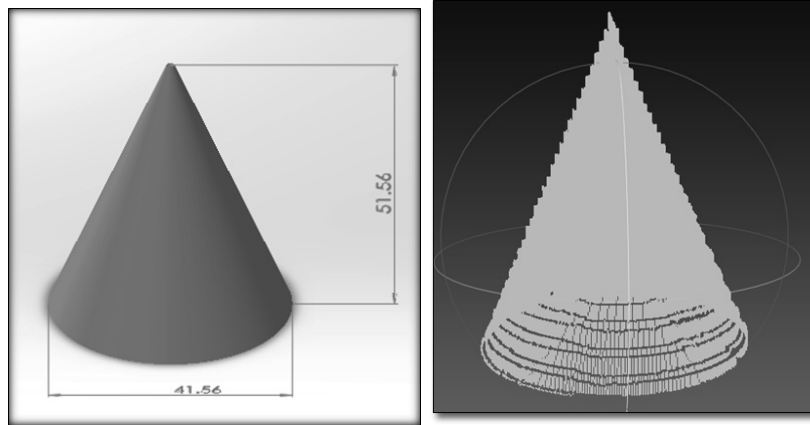

**Figure 9** cone-shaped object. Compared with the scanned model.

In addition, the external light can interfere with the system and has a large effect on the laser reflection due to lower contrast. The laser line in the picture is much

more diffuse and leads to the more difficulty to calculate the exact coordinate. Scanning in the dark without any interference from ambient light will make the better result.

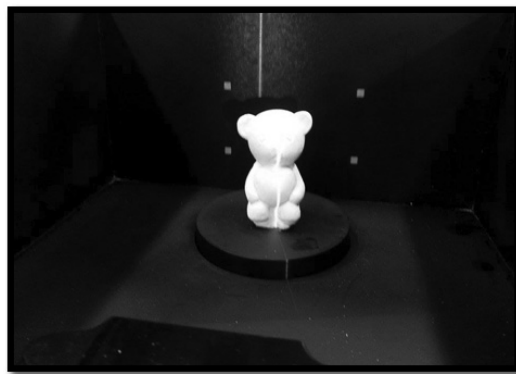

**Figure 10** Ambient light affect the contrast

The result from the experiment with the freeform object show the better result. The 3D model created from the point cloud from the result make the better model.

The dimension is almost the same as the original model and also easy to modify in computer.

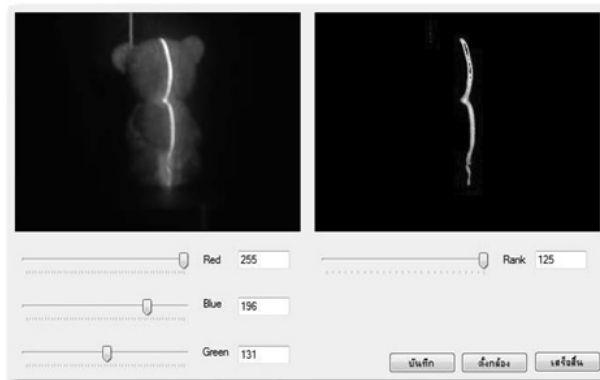

**Figure 11** The suitable contrast allow easily calculated.

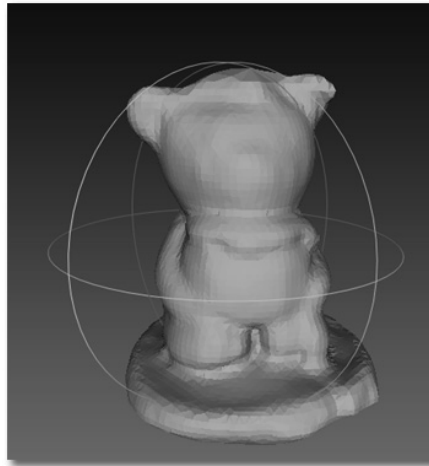

**Figure 12** The 3D model prototypes from machine with error compensate.

## Conclusion

The 3D scanner machine can reproduce the data and create a 3D model from real objects. The machine has a 1 millimeter accuracy due to the limitation of the device, laser and camera. The machine still has some problems with external light interference because of the type of camera. This problem can be solved by using other camera types such as infrared or implemented some image processing algorithm. The nonlinearity of camera picture and lens distortion still affect the result. When we neglect the nonlinearity, it lead to 9.42% result error in normal surface and as high as 23% in a very small surface. When integrate with nonlinearity, the result error reduce to 4.6%. In addition, the research did not consider the results of statistical data<sup>10,18-22</sup>

“type” : “article-journal”,  
“volume” : “66” }, { “uris” : [ “http://www.mendeley.com/documents/?uuid=700d3d45-4e51-4d88-85d7-ce75c-c65615e” ] }, { “id” : “ITEM-3”, “itemData” : { “DOI” : “10.1016/j.optlaseng.2008.09.003”, “ISSN” : “01438166”, “author” : [ { “dropping-particle” : “”, “family” : “Shiou”, “given” : “Fang-Jung”, “non-dropping-particle” : “”, “parse-names” : false, “suffix” : “” }, { “dropping-particle” : “”, “family” : “Liu”, “given” : “Min-Xin”, “non-dropping-particle” : “”, “parse-names” : false, “suffix” : “” } ], “container-title” : “Optics and Lasers in Engineering”, “id” : “ITEM-3”, “issue” : “1”, “issued” : { “date-parts” : [ [ “2009”, “1” ] ] }, “page” : “7-18”, “title” : “Development of a novel scattered triangulation laser probe with six linear charge-coupled devices (CCDs). If we change the direction of the laser to

the landscape as well as increase the number of lasers and scan each plane will coordinate overlapping. The result will be more accurate.

## Reference

- [1] S. Al-kheder, Y. Al-shawabkeh, and N. Haala, Developing a documentation system for desert palaces in Jordan using 3D laser scanning and digital photogrammetry, *J Archaeological Science*, 2009; 36(2): 537-546.
- [2] J. Chen, X. Wu, M. Yu Wang, and X. Li, 3D shape modeling using a self-developed hand-held 3D laser scanner and an efficient HT-ICP point cloud registration algorithm, *Optic and Laser Technology*, 2013; 45: 414-423.
- [3] G. Fu, A. Menciassi, and P. Dario, Development of a low-cost active 3D triangulation laser scanner for indoor navigation of miniature mobile robots, *Robotics and Autonomous System*, 2012; 60: 1317-1326.
- [4] H. González-Jorge, B. Riveiro, P. Arias, and J. Armesto, Photogrammetry and laser scanner technology applied to length measurements in car testing laboratories, *Measurement*, 2012; 45(3): 354-363.
- [5] A. Pesci, M. Fabris, D. Conforti, F. Loddo, P. Baldi, and M. Anzidei, Integration of ground-based laser scanner and aerial digital photogrammetry for topographic modelling of Vesuvio volcano, *J. Volcanology and Geothermal Research*, 2007; 162, 3–4, 123–138.

- [6] C. Sahin, A. Alkis, B. Ergun, S. Kulur, F. Batuk, and A. Kilic, Producing 3D city model with the combined photogrammetric and laser scanner data in the example of TaksimCumhuriyet square, *Optics and Lasers in Engineering*, 2012; 50(12), 1844–1853, Dec.
- [7] A. V. Leonov, M. N. Anikushkin, A. V. Ivanov, S. V. Ovcharov, A. E. Bobkov, and Y. M. Baturin, Laser scanning and 3D modeling of the Shukhov hyperboloid tower in Moscow, *J. Cultural Heritage*, 2014; 16(4): 551-559.
- [8] T. Horiuchi, F. Nohara, and S. Tominaga, Accurate reversible color-to-gray mapping algorithm without distortion conditions, *Pattern Recognition Letters*, Vol. 2010; 31(15): 2405-2414.
- [9] M. Song, D. Tao, C. Chen, J. Bu, and Y. Yang, Color-to-gray based on chance of happening preservation, *Neurocomputing*, 2013; 119: 222-231.
- [10] M. Torabi, S. M. Mousavi G., and D. Younesian, A new methodology in fast and accurate matching of the 2D and 3D point clouds extracted by laser scanner systems, *Optical and Laser Technology*, 2015; 66, 28–34, 2015.
- [11] Y. Liu, Automatic registration of overlapping 3D point clouds using closest points, *Image and Vision Computing*, 2006; 24(7), 762–781.
- [12] B. He, Z. Lin, and Y. F. Li, An automatic registration algorithm for the scattered point clouds based on the curvature feature, *Optical and Laser Technology*, 2013; 46, 53–60.
- [13] V. V. Lehtola, J.-P. Virtanen, A. Kukko, H. Kaartinen, and H. Hyypä, Localization of mobile laser scanner using classical mechanics, *ISPRS J. Photogrammetry and Remote Sensing*, 2015; 99, 25–29.
- [14] V. Lombardo and T. Marzulli, A time-of-scan laser triangulation technique for distance measurements, *Optics and Lasers Engineering*, Vol. 2003; 39, 247–254.
- [15] A. L. Reyes, J. M. Cervantes, and N. C. Gutiérrez, Low Cost 3D Scanner by Means of a 1D Optical Distance Sensor, *Procedia Technology*, 2013; 7, 223–230.
- [16] A.-I. García-Moreno, D.-E. Hernández-García, J.-J. González-Barbosa, A. Ramírez-Pedraza, J. B. Hurtado-Ramos, and F.-J. Ornelas-Rodríguez, Error propagation and uncertainty analysis between 3D laser scanner and camera, *Robotics and Autonomous System*, 2014; 62(6) 782–793.
- [17] B. Muralikrishnan, W. Ren, D. Everett, E. Stanfield, and T. Doiron, Performance evaluation experiments on a laser spot triangulation probe, *Measurement*, 2012; 45(3) 333–343.
- [18] L. Zeng, F. Yuan, D. Song, and R. Zhang, A two-beam laser triangulation for measuring the position of a moving object, *Optics and Lasers Engineering*, 1999; 31, 445–453.
- [19] F.-J. Shiou and M.-X. Liu, Development of a novel scattered triangulation laser probe with six linear charge-coupled devices (CCDs), *Optics and Lasers Engineering*, 2009; 47(1): 7-15.
- [20] Ş. Ozan and Ş. Gümüştekin, Calibration of double stripe 3D laser scanner systems using planarity and orthogonality constraints, *Digital Signal Processing*, 2014; 24:231-243.
- [21] R.-T. Lee and F.-J. Shiou, Multi-beam laser probe for measuring position and orientation of freeform surface, *Measurement*, 2011; 44(1): 1-10.
- [22] F. J. Brosed, J. Santolaria, J. J. Aguilar, and D. Guilomía, Laser triangulation sensor and six axes anthropomorphic robot manipulator modelling for the measurement of complex geometry products, *Robotics and Computer Integrated Manufacturing*, 2012; 28(6): 660-671.